

POLYESTER NON WOVEN TAPES

Poliester non-woven fabric

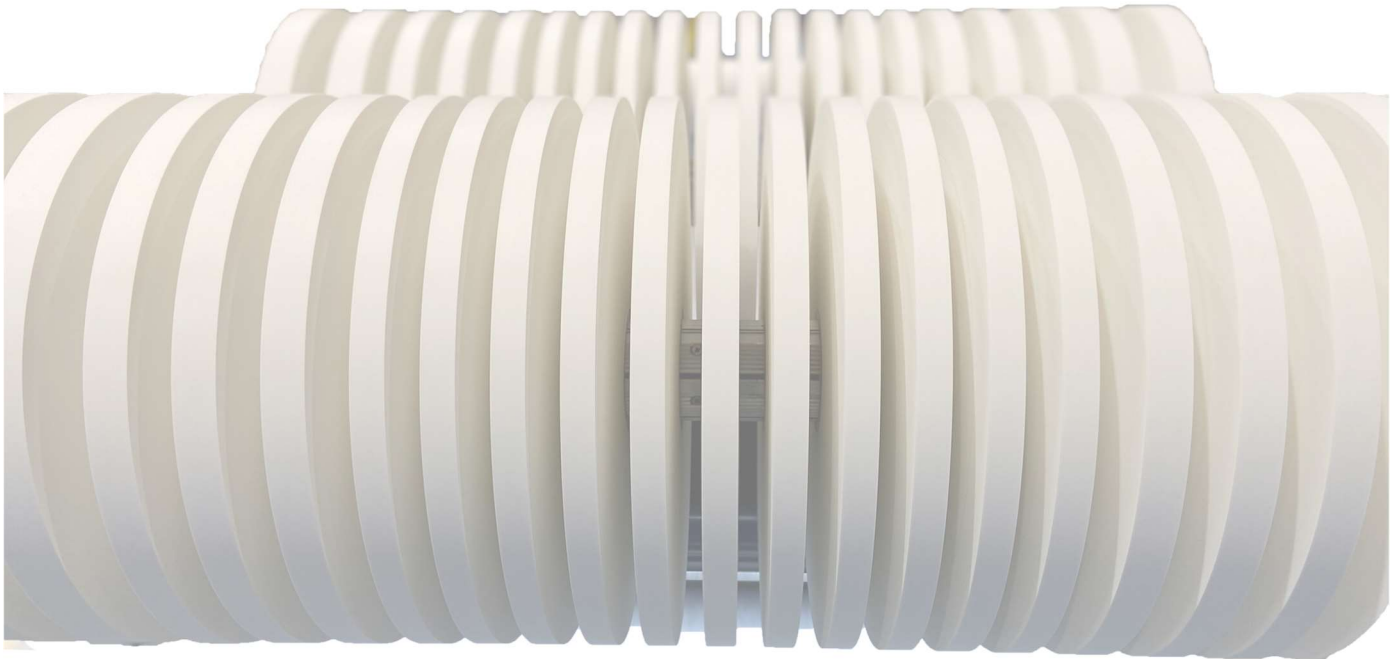

Separating films used for binding and as a solution for peeling cables between cable components.



Technical Values

Properties	Test Method	NWP-04	NWP-05	NWP-06	NWP-09	NWP-12	NWP-16	NWP-20
Thickness μm	ISO 9073-2	40	50	60	90	120	160	200
Yield g/m^2	ISO 9073-1	20 \pm 2	25 \pm 3	30 \pm 3	40 \pm 3	50 \pm 3	60 \pm 4	70 \pm 5
Tensile Strength N/cm	ISO 9073-3	\geq 20	\geq 25	\geq 28	\geq 38	\geq 43	\geq 40	\geq 55
Elongation at break %	ISO 9073-3	\geq 10	\geq 10	\geq 12	\geq 12	\geq 12	\geq 12	\geq 12
Short term stability $^{\circ}\text{C}$	Q/TR.J02.031-2000	230	230	230	230	230	230	230
Long term stability $^{\circ}\text{C}$	IEC 216	90	90	90	90	90	90	90
Moisture content %	ISO 287	\leq 5	\leq 5	\leq 5	\leq 5	\leq 5	\leq 5	\leq 5

Packaging presentations

Pads/Rolls

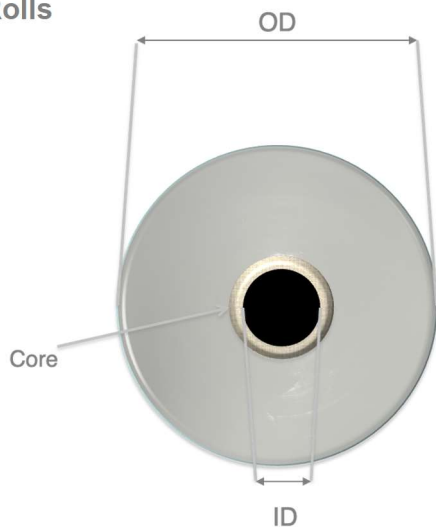

ID Typical values: 76 (3 inch), 102 (4.5 inch), 152 (6 inch)
 Other ID available on demand. Contact us.
 OD Typical values: From 80-600 mm
 Core: Plastic or carton, different thicknesses available
 Widths: from 10 to 1000 mm

Traverse Wounded Spool or Step to Step spool

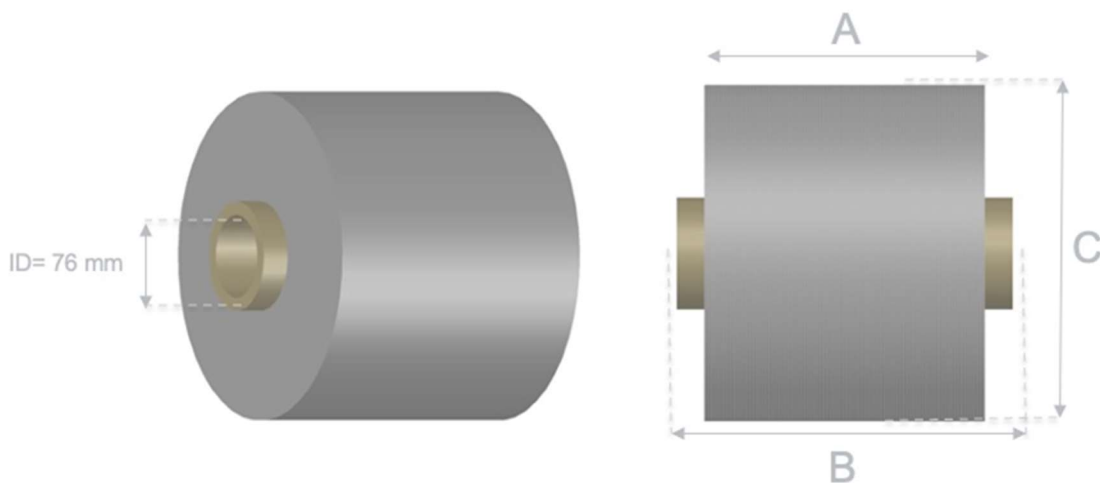

ID Typical values: 76 (3 inch)
 OD Typical values: Up to 300-320 mm
 Core: Plastic or carton, different thicknesses available.
 Pre-cut versions cores available.
 Widths: from 10 to 100 mm